

Diaphragm Accumulators

AD Series

IN THIS SECTION

Overview	65
Specifications	66
Models, Capacities & Dimensions	67
Options & Accessories	68
Ordering Information	69

Diaphragm



Features

- Operating Pressures to 250 Bar
- Capacities from .075 to 2.80 Liters
- Compact and Lightweight
- Low Cost, Non-Repairable Design
- Hydrin Diaphragms
- Durable Metric Gas Valve

Introduction

Diaphragm accumulators provide an affordable means of enhancing the performance of a hydraulic system. They are suitable for storing energy under pressure, absorbing hydraulic shocks, and dampening pump pulsation and flow fluctuations. Diaphragm accumulators provide dependable performance, maximum efficiency, and long service life in a lightweight, compact design.

Why Use Diaphragm Accumulators?

- improves system efficiency
- supplements pump flow
- supplies power in emergency
- compensates for leakage
- absorbs hydraulic shocks
- very contamination tolerant
- cost effective
- compact, lightweight
- safety, non-repairable design
- very quick response
- works well with water, low lubricity fluids

**Parker Diaphragm Accumulators...
Your #1 Choice!**

Parker is the leading manufacturer of accumulators in North America. Parker's broad standard offering includes piston, bladder and diaphragm accumulators. For your convenience, Parker offers the latest in accumulator sizing technology with its *inPHorm Accumulator Sizing and Selection Software*.

Specifications

Materials

- Shell – high strength alloy steel
- Ports – steel
- Button – Delrin
- Gas Valve Stem – steel
- Diaphragms – Hydrin (ECO)

Max. Compression Ratio (max. working pressure/precharge pressure):
 8 to 1 on .075 liter through 1.4 liter;
 4 to 1 on 2 liter and larger

Maximum Flow Rates

Size (liters)	Maximum Recommended Flow Rates			
	Normal Operation		When Fully Discharging	
	LPM	GPM	LPM	GPM
0.075, 0.16	40	11	10	2.6
0.32 to 1.40	100	26	40	11
2.00 to 2.80	160	42	60	16

Pressure Ratings – See Models, Capacities and Dimensions for pressure ratings by size, all rated at minimum 4 to 1 design factors.

Fluids – Parker's diaphragm accumulators are compatible with most petroleum-based industrial or water-based flame resistant fluids. See diaphragm material options or consult factory for details.

Precharge – Units are shipped with a nominal nitrogen precharge as standard. For specific precharge pressure, specify charge pressure at the time of order.

Available Options

- Diaphragm Compounds
- Gas Valves – M28 x 1.5 standard
 – ISO 4570-8VI gas valve (consult factory)
- Hydraulic Ports – SAE standard
 – others (consult factory)



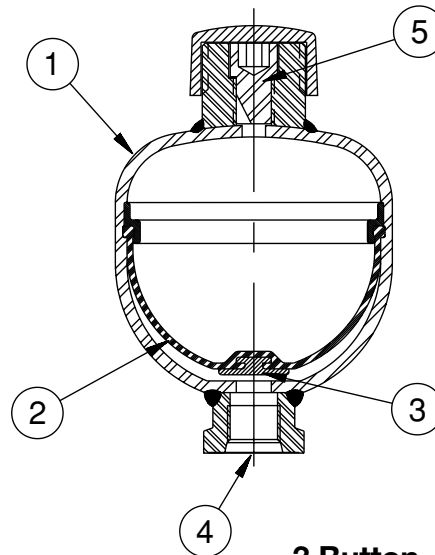

1 Shell

The shell is manufactured from a high strength alloy steel. The non-repairable electron-beam welded construction reduces size, weight, and, ultimately, initial cost.

2 Diaphragm

The flexible diaphragm provides excellent gas and fluid separation. Diaphragms are available in Hydrin (ECO) compound which provides excellent service with most mineral fluids. ECO offers excellent low-temperature performance for mobile applications.

3 Button

The button closes the fluid port when the accumulator is fully discharged to prevent diaphragm extrusion, a low cost alternative to more complex and expensive valve-spring designs.

4 Fluid Port

SAE straight thread for easy installation and leak-free service.

5 Gas Valve

Metric M28X1.5 gas valve is durable, leak-free and offers the flexibility of checking or charging the accumulator. See page 102 for charging and gauging accessories. U.S. Gas Valve is also available. See model numbering information.

Models, Capacities and Dimensions

Model	Size	MOP ¹	A	B	C	D	E	F	Weight
	liters (cu in)	bar (PSI)	mm (in.)					Port (thread)	kg. (lb.)
AD007A25T9A1	0.075 (5)	250 (3600)	111 (4.37)	20 (0.79)	64 (2.52)	30 (1.18)	32 (1.26)	SAE #6 (9/16 - 18)	0.65 (1.4)
AD016A25T9A1	0.16 (10)	250 (3600)	120 (4.72)	20 (0.79)	75 (2.95)	32 (1.26)	32 (1.26)	SAE #6 (9/16 - 18)	1.0 (2.2)
AD032A16T9A1	0.35 (20)	160 (2300)	136 (5.35)	22 (0.87)	92 (3.62)	63 (2.48)	41 (1.61)	SAE #8 (3/4 - 16)	1.3 (2.9)
AD050A16T9A1	0.50 (30)	160 (2300)	149 (5.87)	22 (0.87)	103 (4.06)	70 (2.76)	41 (1.61)	SAE #8 (3/4 - 16)	1.5 (3.3)
AD075A18T9A1	0.75 (45)	180 (2600)	166 (6.54)	22 (0.87)	121 (4.76)	78 (3.07)	41 (1.61)	SAE #8 (3/4 - 16)	2.6 (5.7)
AD075A25T1A1	0.75 (45)	250 (3600)	173 (6.81)	22 (0.87)	127 (5.00)	81 (3.19)	41 (1.61)	SAE #8 (3/4 - 16)	3.2 (7.1)
AD100A20T9A1	1.00 (60)	200 (2900)	180 (7.09)	22 (0.87)	136 (5.35)	63 (2.48)	41 (1.61)	SAE #8 (3/4 - 16)	3.5 (7.7)
AD140A25T9A1	1.40 (85)	250 (3600)	198 (7.80)	22 (0.87)	155 (6.10)	72 (2.83)	41 (1.61)	SAE #8 (3/4 - 16)	6.0 (13)
AD200A25T9A1	2.00 (120)	250 (3600)	251 (9.88)	22 (0.87)	155 (6.10)	72 (2.83)	41 (1.61)	SAE #8 (3/4 - 16)	7.5 (17)
AD280A25T9A1	2.80 (170)	250 (3600)	268 (10.6)	22 (0.87)	174 (6.85)	87 (3.43)	41 (1.61)	SAE #8 (3/4 - 16)	10 (22)

¹Maximum Operating Pressure.

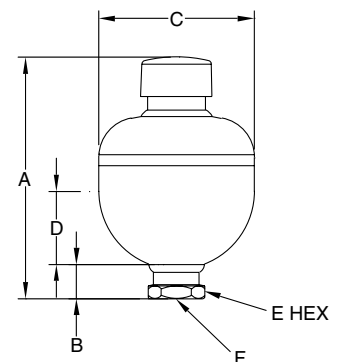

Metric Gas Valve

Parker AD Series diaphragm accumulators are fitted as standard with metric M28X1.5 gas valves. This rugged gas valve features a internal hex locking screw with sealing washer. Charging and pressure checking can be accomplished by utilizing the M28X1.5 charging and gauging assembly shown in Accumulator Accessories.

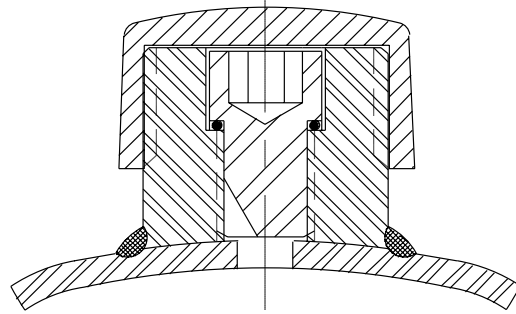

U.S. Gas Valve

Parker AD Series diaphragm accumulators can be fitted with an optional US gas valve. The US gas valve features an internal gas valve core and a sealing washer. Charging and pressure checking can be accomplished by utilizing standard charging and gauging assembly as shown in Accumulator Accessories.

Assembly Part No. L08700150A

Item	Part No.	Qty.	Description
1	148146 0000	1	Protective Cover
2	087036 0031	1	Dyna Seal
3	582222 0000	1	Valve Core
4	135238 0000	1	Gas Valve Housing
5	870016 0000	1	Gas Valve Seal

Assembly Part No. L087001500

Item	Part No.	Qty.	Description
3	582222 0000	1	Valve Core
4	135238 0000	1	Gas Valve Housing
5	870016 0000	1	Gas Valve Seal

NOTE: For assembly of gas valve to cap, use 9 ft/lbs.

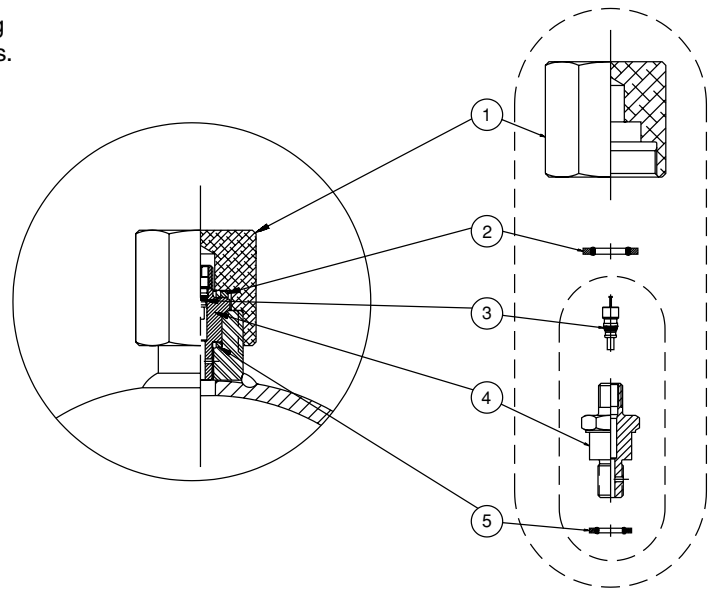

Standard Diaphragm Materials

The following table lists Hydrin's recommended operating temperature ranges and the types of fluids that are generally compatible.

Seal Code	Polymer	Recommended Operating Temperature Range	Maximum Temperature with Reduced Life	General Application & Compatibility ¹
9	Hydrin (Lo-Temp)	-40°F to 176°F -40°C to 80°C	200°F 93°C	Compatible with most mineral oil based fluids and maintains flexibility at low temps

¹ Consult your local Parker distributor or the factory for fluid compatibility information. Temperature ranges may vary depending upon the fluid used in the hydraulic system.

How to Order Diaphragm Accumulators

AD Series diaphragm accumulators can be specified by using the symbols in the chart below to develop a model number. Select only those symbols that represent the features desired, and place them in the sequence indicated by the example at the top of the chart.

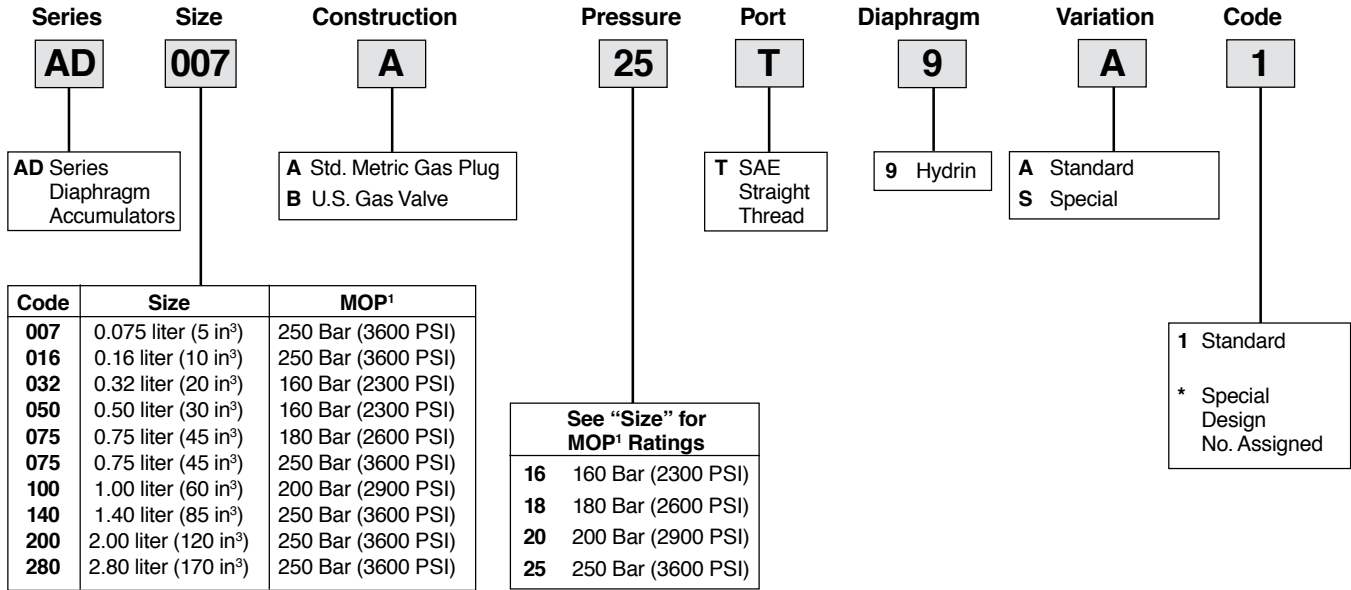

¹ Maximum Operating Pressure

Diaphragm

Notes
